



Yoke Vans.

Racking Unit Assembly Guide

This guide will help you assemble your racking units. Read through the construction section first and then head to the assembly pages to build your unit. Make sure you read through the information first and if you have any questions you can always contact us.

To find out how to install your racking units, head to our racking installation guide.

Contents

Construction	4
Combo Units	6
Individual Units	8

Construction

We have designed our products to make them easy to assemble. They utilise a simple tongue & slot mechanism to allow the components to slot together. Once slotted together, simply use screws to secure the components in place.

To assemble you will need an impact driver and PZ2 drive bit.

Good practice

- Check the pre-drilled screw holes are visible from both sides of the component before assembly, poke through with a drill if not.
- When fixing components together using screws, always pre-drill using a 3mm drill bit and preferably with a countersink for the screw head too.

Tips

- The components can sometimes require a small amount of gentle encouragement using a rubber mallet.

Required tools

- Impact Driver
- PZ2 Drive Bit

Recommended tools

- Combi Drill
- 3mm drill bit with countersink
- Rubber Mallet



4x40mm Wood Screws

Use these screws to join the plywood components of your racking units together.

It is strongly recommended to pre-drill using a 3mm countersunk drill bit before driving the wood screws in.



Rubber Mallet

Simply use a white rubber mallet if the parts are a snug fit.

Combo Units

Our combo units combine multiple individual racks. They are built in sections which are then joined together using pre-machined holes.

Important Information

The order of the uprights can be determined using the number of notches at the bottom on the rear edge. These go from 0 nearest the rear doors to the highest number nearest the bulkhead.

The combo unit shown is built in 2 sections. There may be more sections depending on your particular vehicle.

There is a partition upright built into the left-hand side section on this particular combo unit. Your combo unit may vary. Refer to the product images on our website of your product to see your exact layout.

The flats are designed to only fit correctly into their respective uprights.

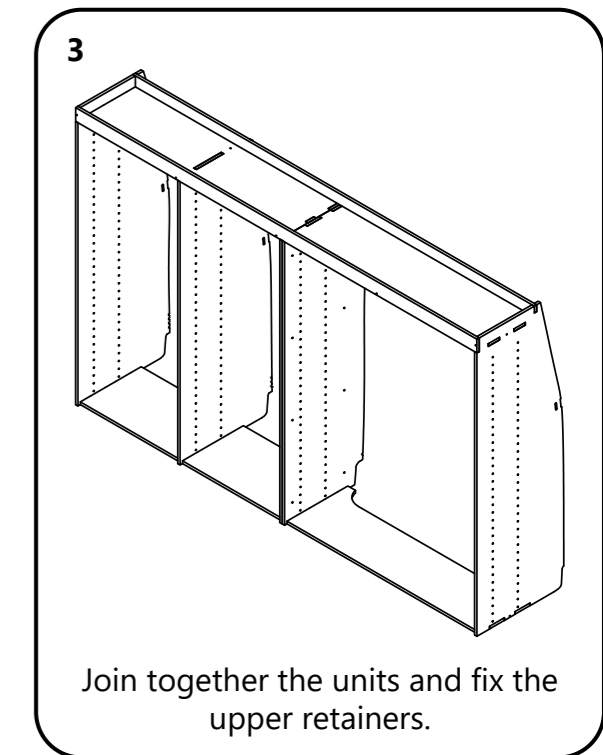
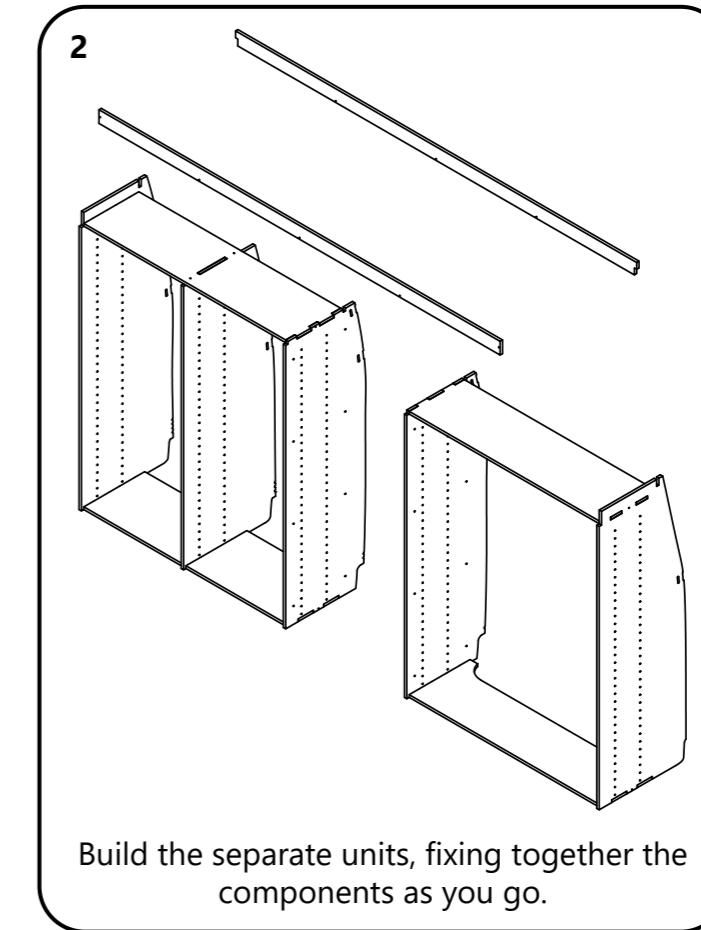
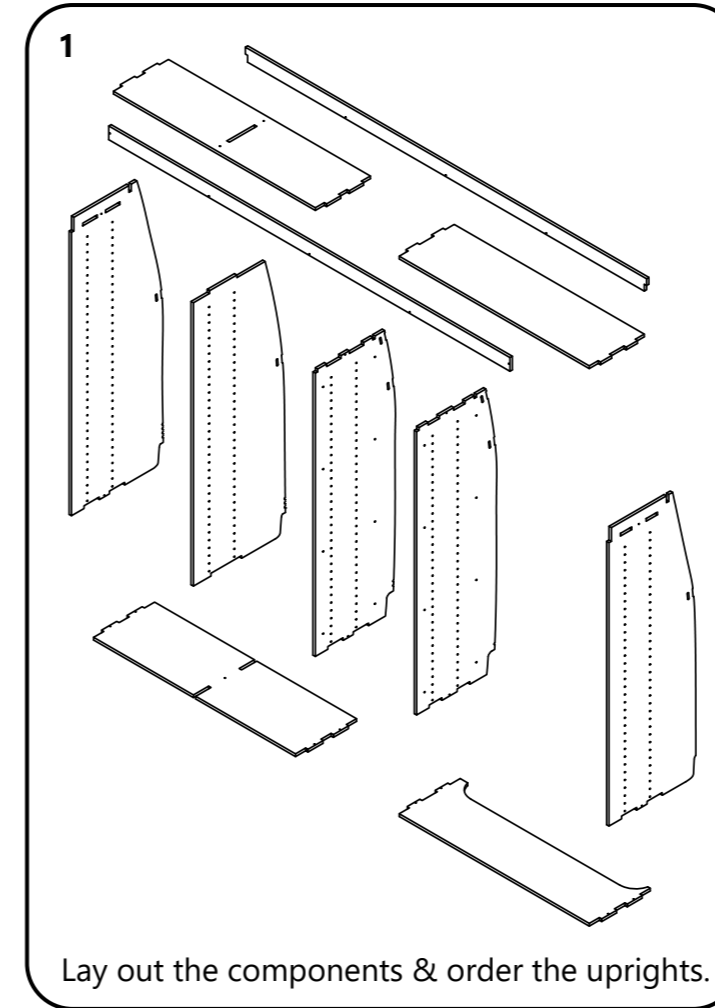
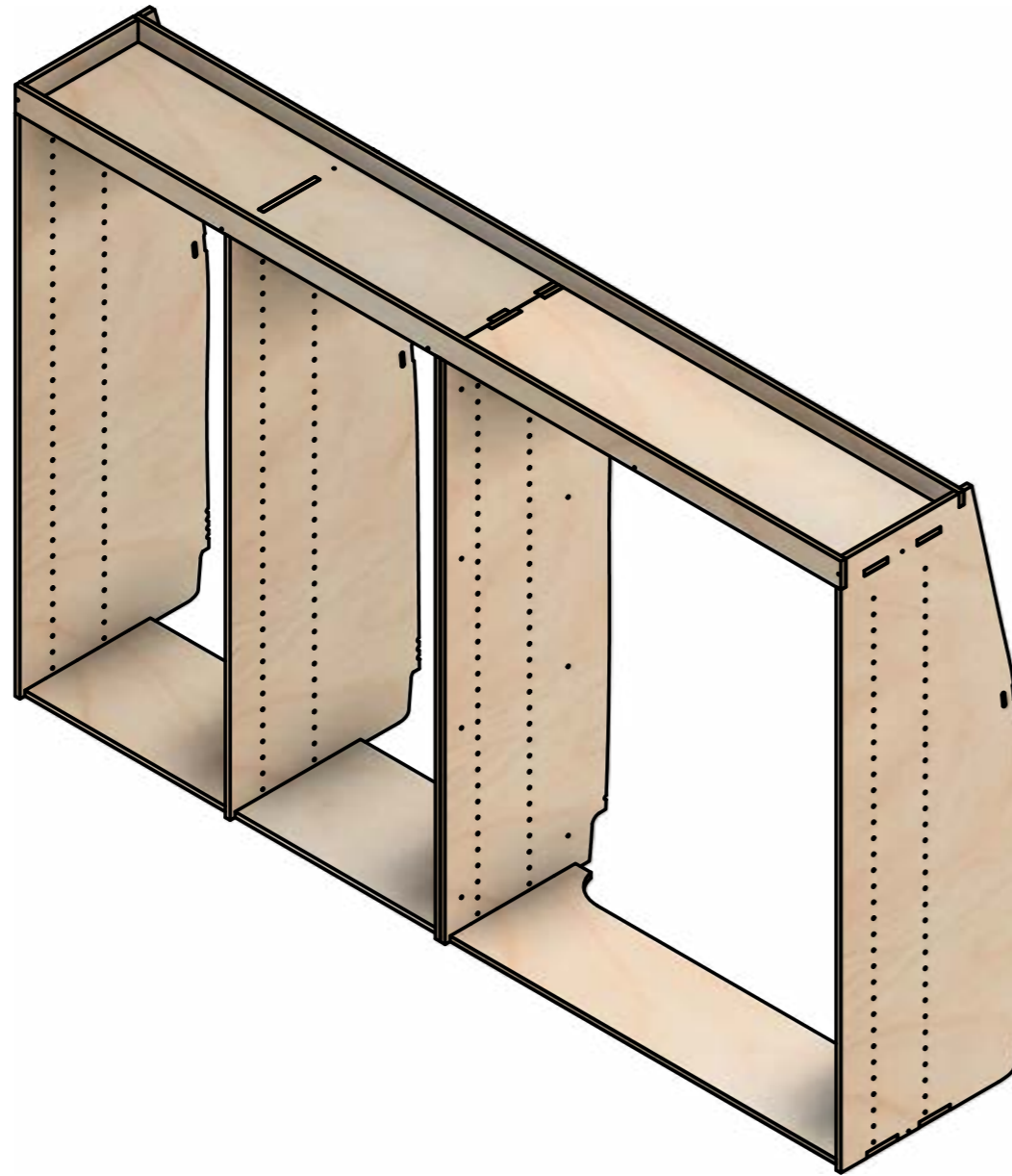

Individual Units

Our individual units are made using 2 uprights, an upper & lower flat, and 2 upper retainers. Once this has been constructed, it can receive a number of different module types. These are often a great addition to the passenger-side wheel arch area.

Important Information

The order of the uprights can be determined using the number of notches at the bottom on the rear edge. These go from 0 nearest the rear doors to the highest number nearest the bulkhead.

The flats are designed to only fit correctly into their respective uprights.

Your unit may vary in appearance to the one shown. However, the same construction steps and principles apply.

Refer to the beginning of this guide for our construction methodology.

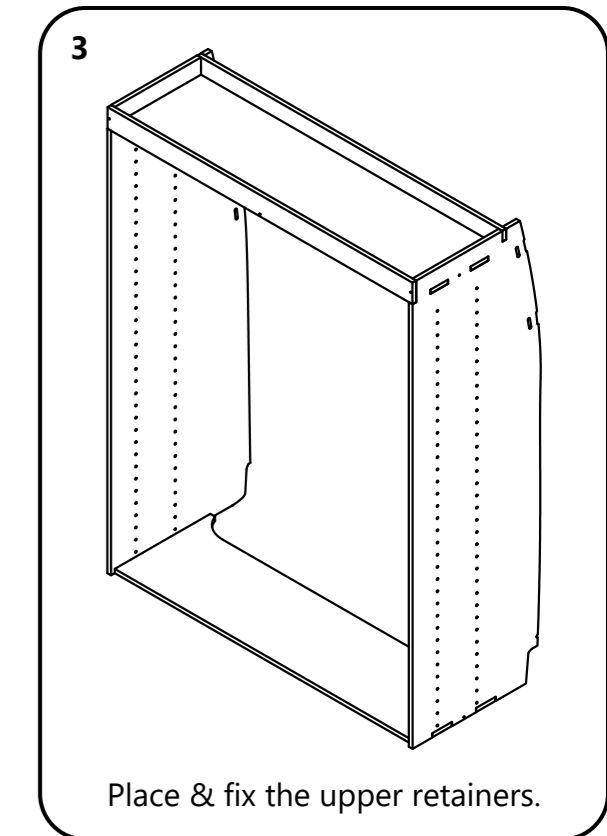
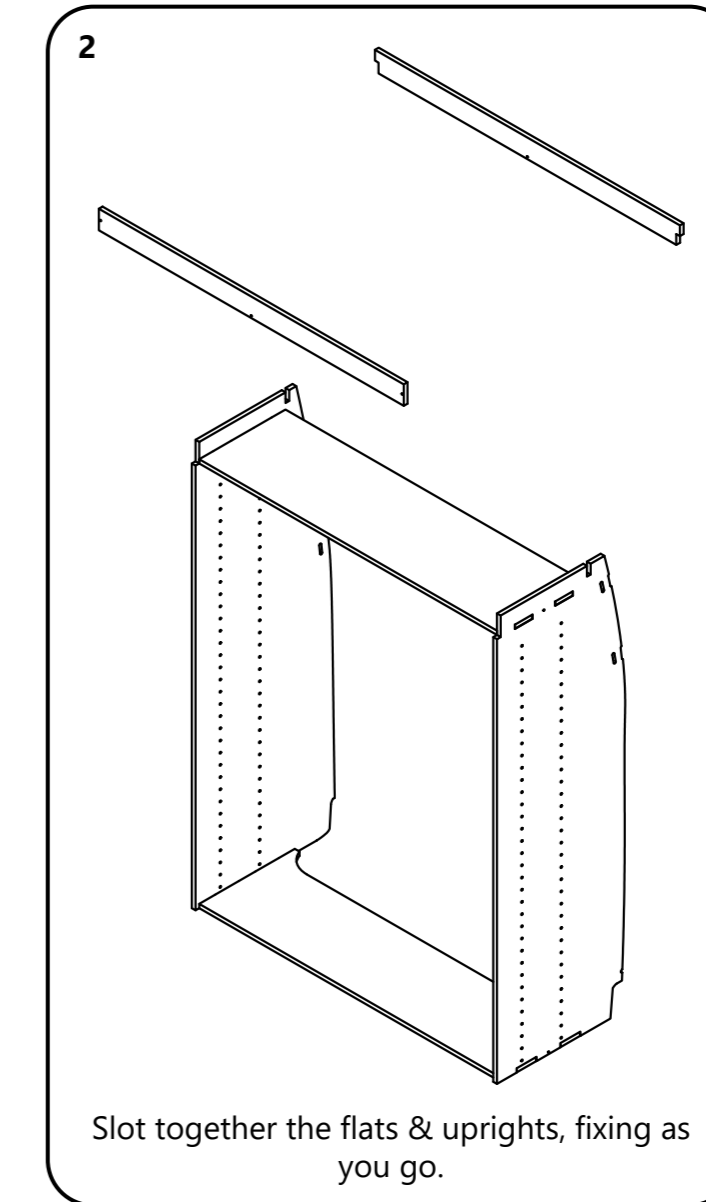
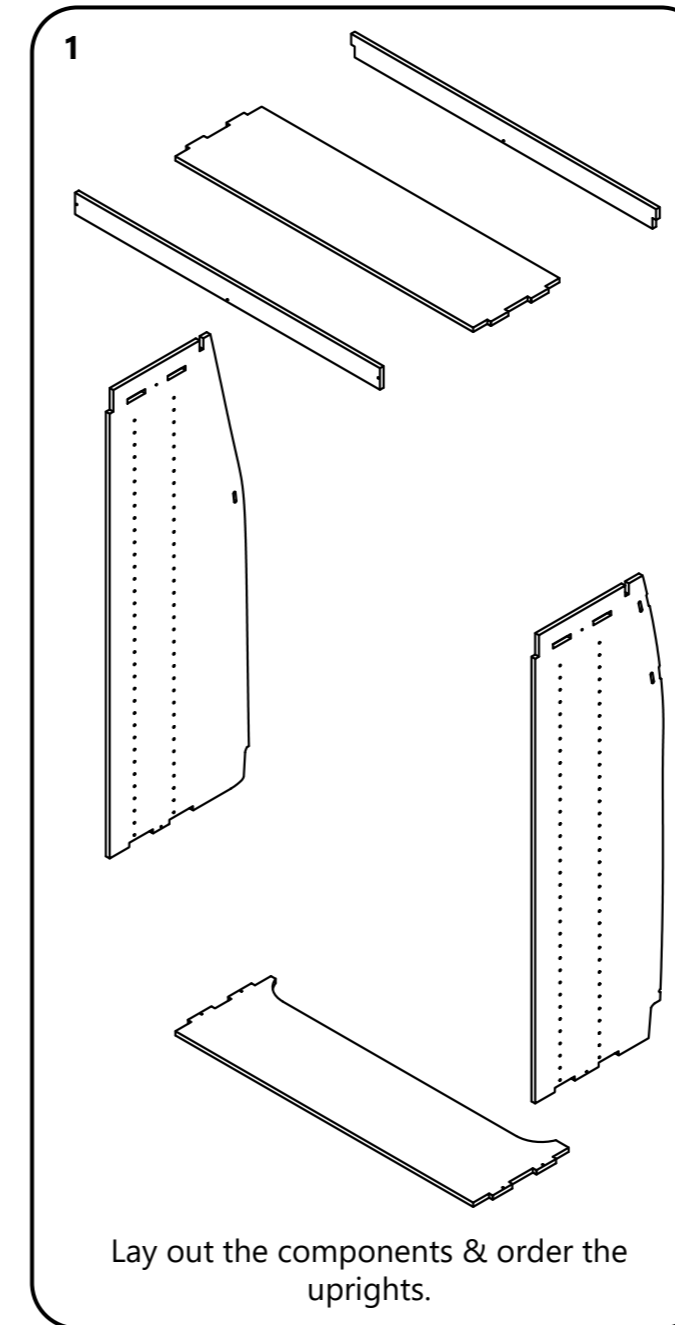
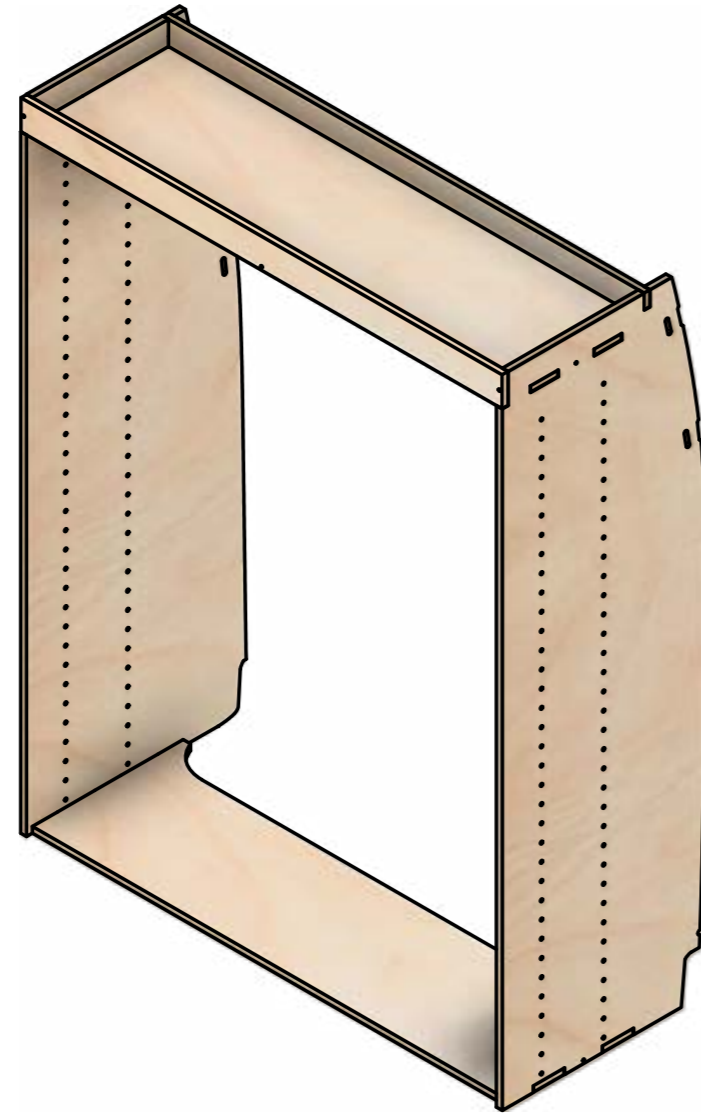

Yoke Vans

info@yoke-van-kits.co.uk

020 8132 9221