



Yoke Vans.

Module Installation Guide

Helpful Information - Read before beginning

Introduction

This document helps guide you through the process of installing modules into your racking system. Our system uses 4 types of module tools. These are used to align & strengthen the modules to the uprights before fixing modules in place.

The modules should be fixed using the provided counter-sunk machine screws. These come in 2 lengths. The longer machine screw should be used when 2 modules on either side of a single partition require the use of the same hole. The longer screws should be driven from one side through both module sides.

Read through the mounting tools page first before finding the module you wish to install further in the guide.

Required tools

- Impact Driver

- 5mm Hex Drive Bit

Recommended tools

- Rubber Mallet

Contents

Mounting Tools	4
Slanted/Angled Module	6
Bare Bones Module	8
Euro Container Module - OU	10
Euro Container Module	12
Dual Slanted Open Underside	14
Organiser Module	16
Retainer	18

Mounting Tools

Our mounting tools are used to align & strengthen the modules in your racking. There are 4 different types, 2 for flat modules and 2 for angled/slanted modules, which can be seen on the next page. Each type of module has an associated mounting tool, which can be seen on the module page.

Using the mounting tools

Get your mounting tools in pairs. The angled mounting tools have a left & right. The profile on the top edge will be towards the front edge of the racking.

Insert the mounting tool on each side of the upright you wish to mount a module within. Ensure that both tools are level and oriented correctly.

If your mounting tool has added holes below the pins, use these to fix the mounting tool to the uprights with the included countersunk machine screws.

Proceed to install the modules as seen further along this document.

Tips & Helpful Information

The mounting tools should be a snug fit and require a little bit of a push to be inserted into the upright holes.

If the pin does not go all the way in on a partition panel with a module on the other side, unscrew the module screws slightly and re-tighten the screws after fitting the new module.

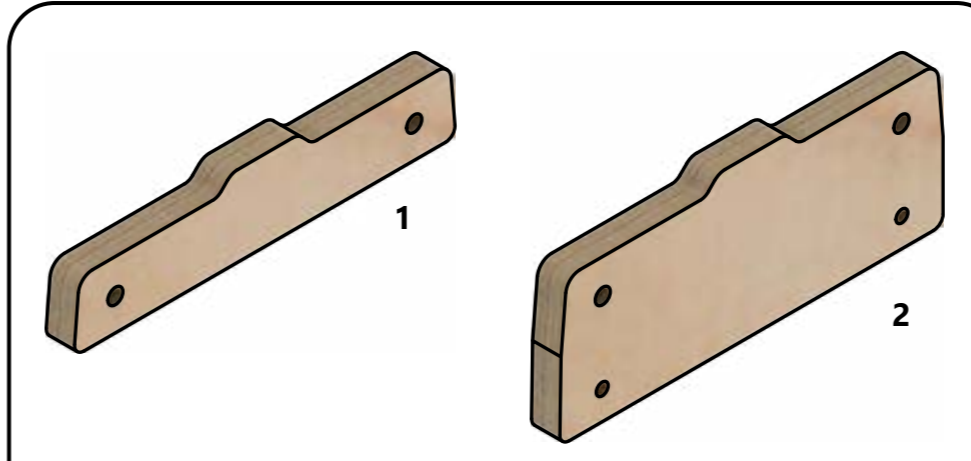

Flat Mounting Tools

The flat mounting tools are used to align & strengthen flat modules. They are symmetrical, therefore they can be used on either side of the module

The smaller tool (1) is for use on shorter-span flat modules such as the 504W Bare Bones.

The larger drop down tool (2) is for use on longer-span modules such as Organiser modules. The extra holes below the pins should be used to fix the tool to the upright, using the counter sunk machine screws, for added strength.

Slanted Mounting Tools

The angled mounting tools are used to align & strengthen angled/slanted modules. They are not symmetrical and therefore have a left & right.

The profile on the top edge of the tool should always be towards the front of the racking.

The smaller tool (3) is for use on shorter-span flat modules such as the 504W Slanted Shelf.

The larger drop down tool (4) is for use on longer-span modules. The extra holes below the pins should be used to fix the tool to the upright, using the counter sunk machine screws, for added strength.

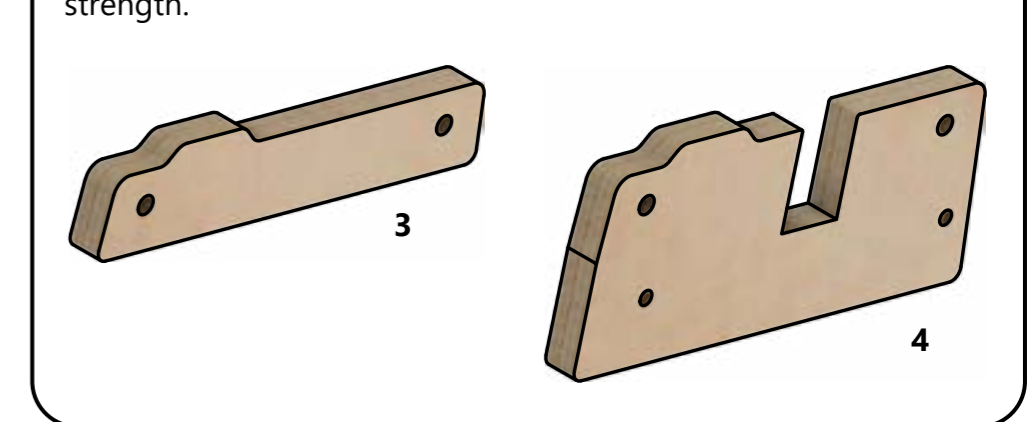

Slanted/Angled Module

The slanted/angled modules use the smaller angled mounting tool.

The countersunk holes on the module sides should be used to fix the module to the uprights using the countersunk machine screws provided.

Tips & Tricks

If mounting either side of a single upright, using the same upright holes, then use longer machine screws to go through both modules from one side.

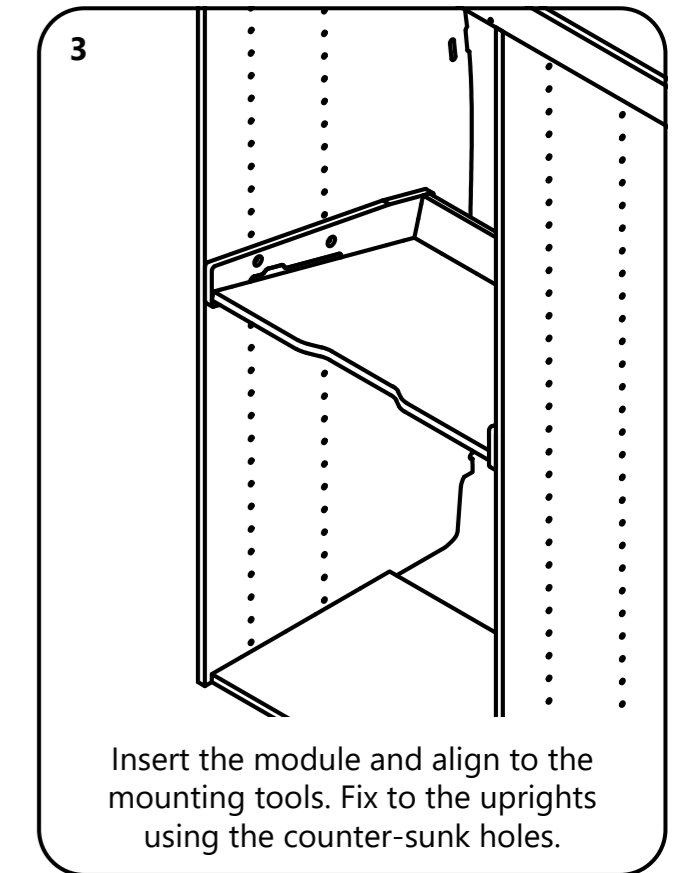
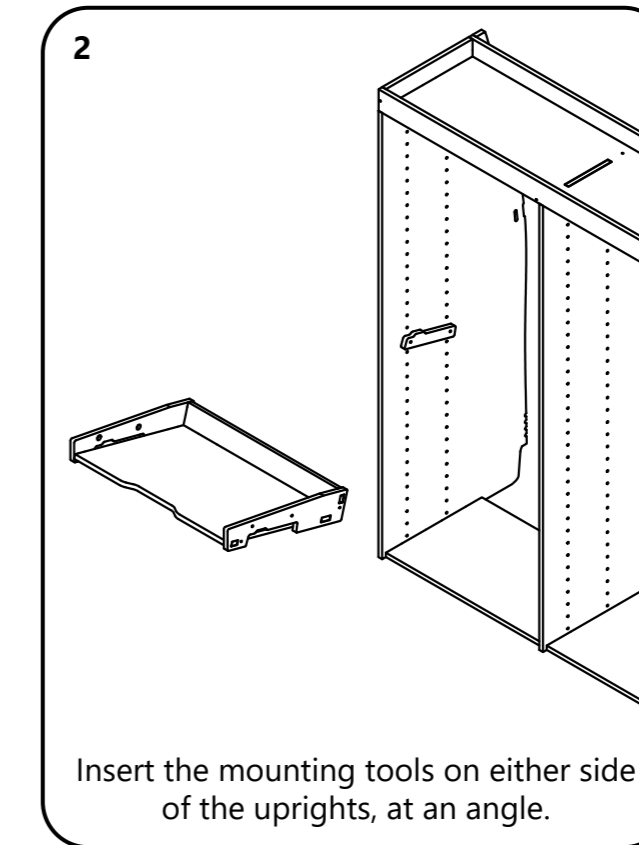
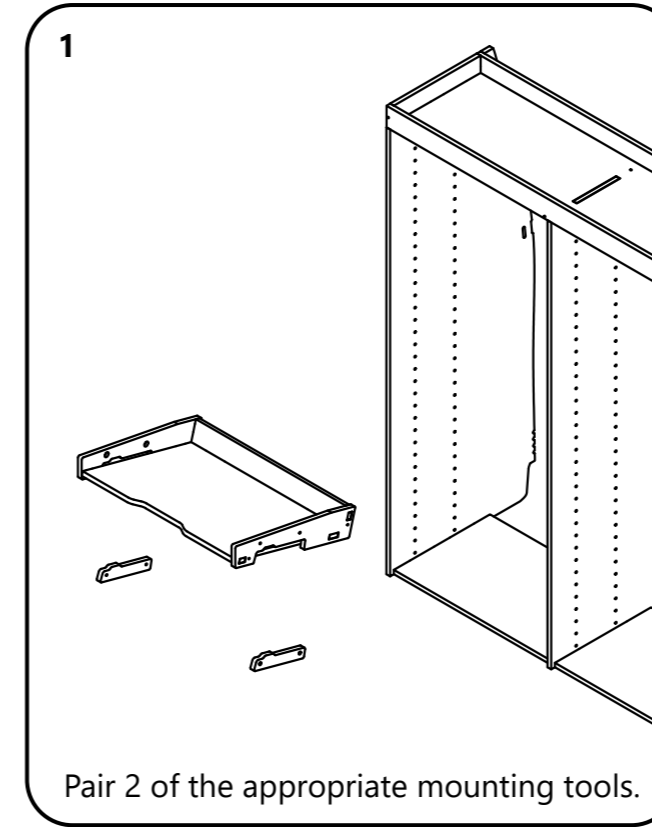
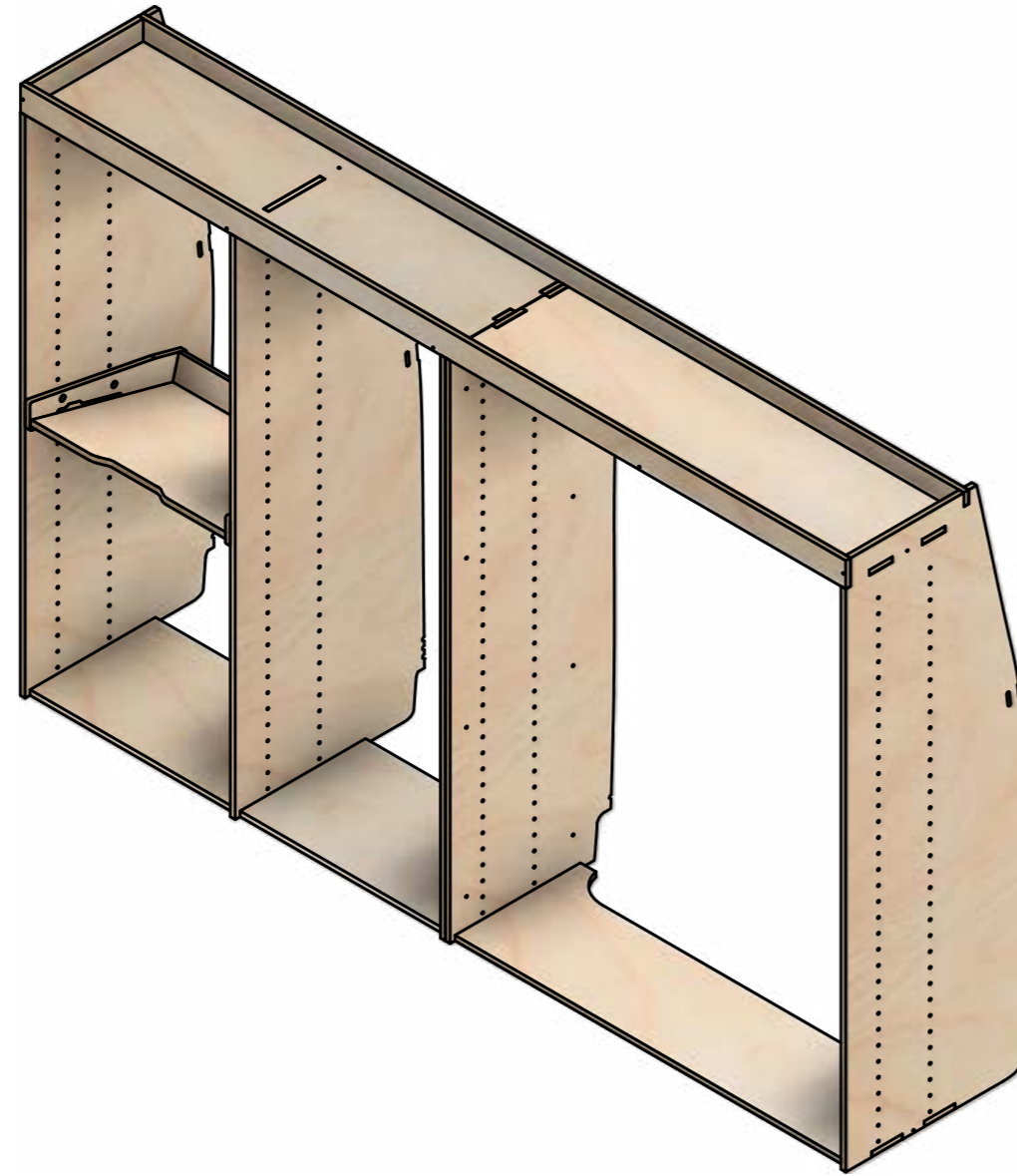
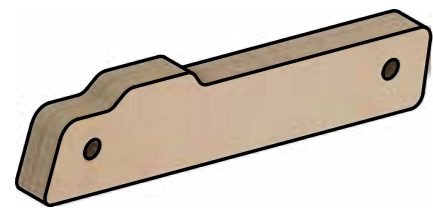

Bare Bones Module

The Bare Bones module uses the flat mounting tools. These are symmetrical and do not have a specific left/right tool.

Once the module is in place, use the holes in the module sides to fix to the uprights.

Tips & Tricks

If mounting either side of a single upright, using the same upright holes, then use longer machine screws to go through both modules from one side.

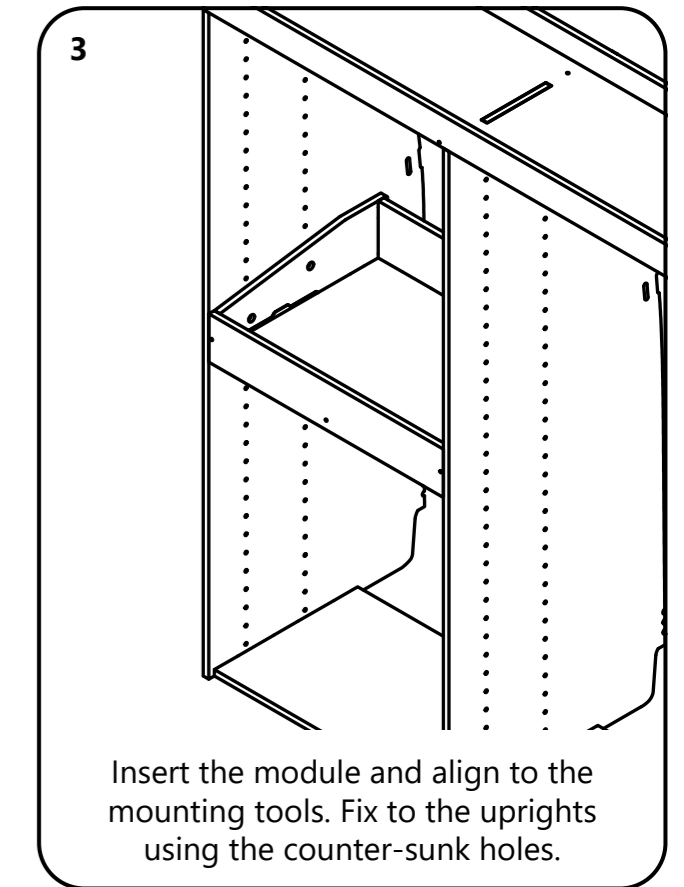
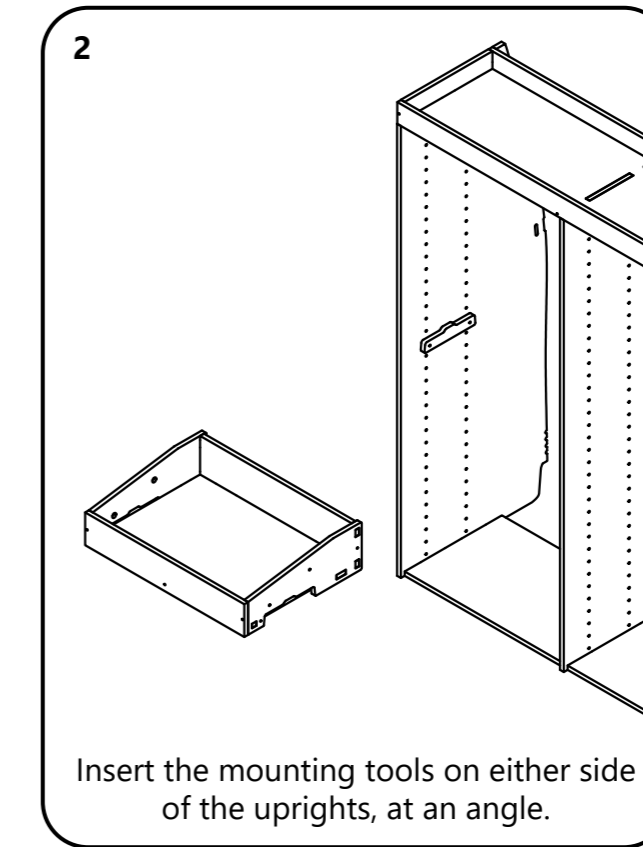
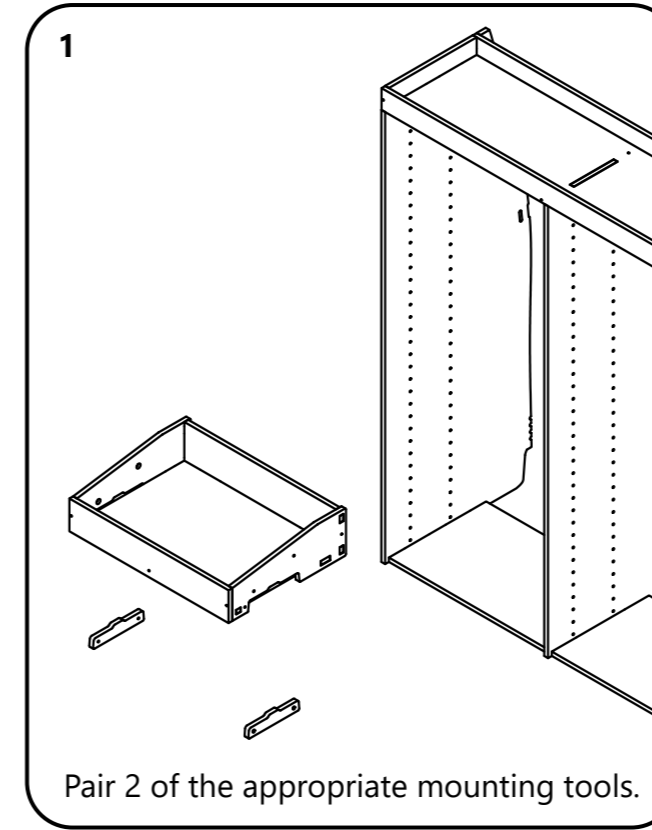
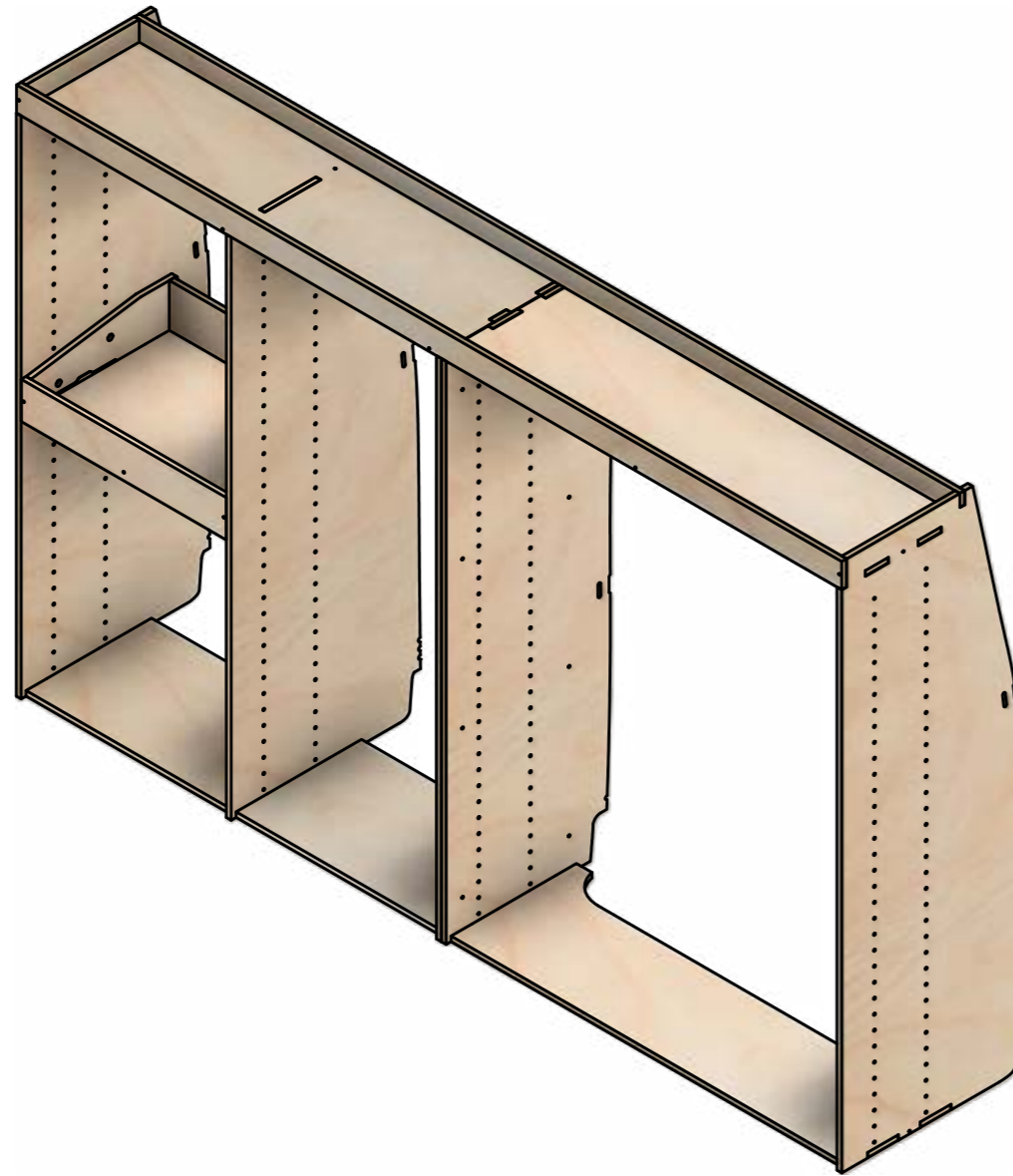
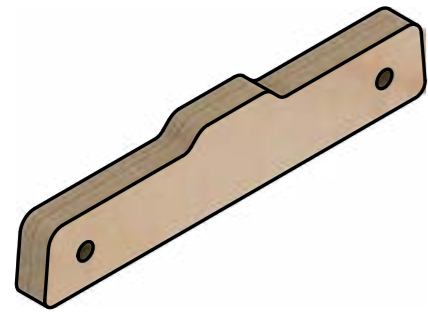

Euro Container Module - Open Underside

If your module has underside clearance, use the larger angled mounting tools with cross supports. If your module sits on the racking base, use the smaller angled mounting tools.

Use the extra holes to fix the mounting tool to the upright for added support.

Once the module is in place, use the holes in the module sides to fix to the uprights.

Tips & Tricks

Ensure the module partitions rest on the base of the unit.

If mounting with underside clearance, always use the relevant cross supports.

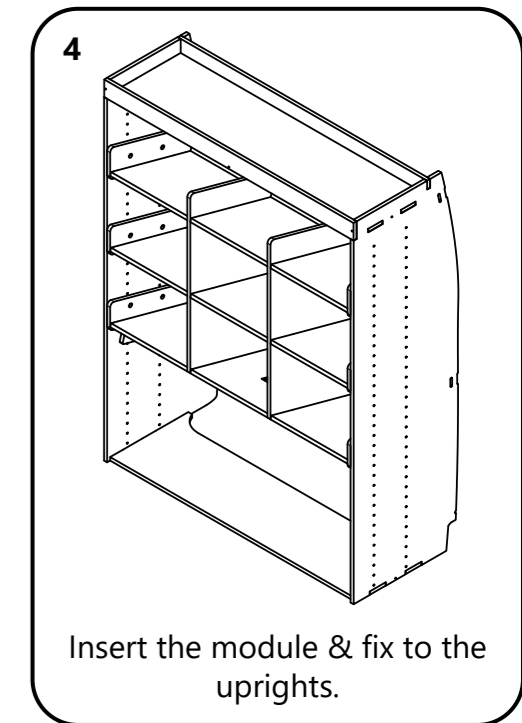
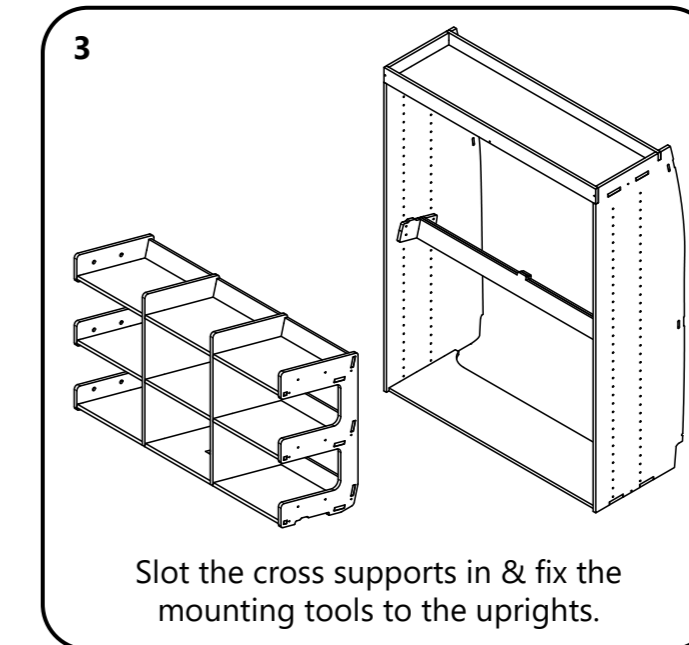
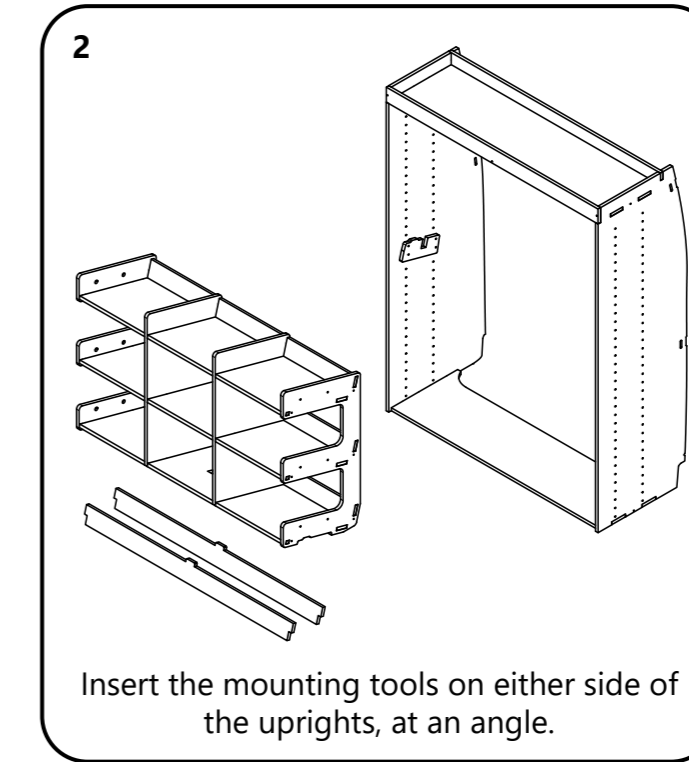
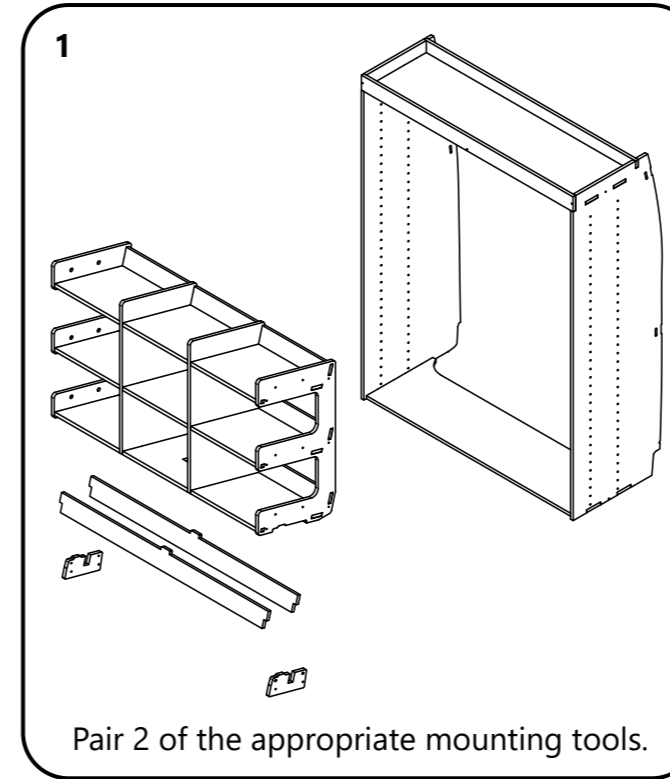
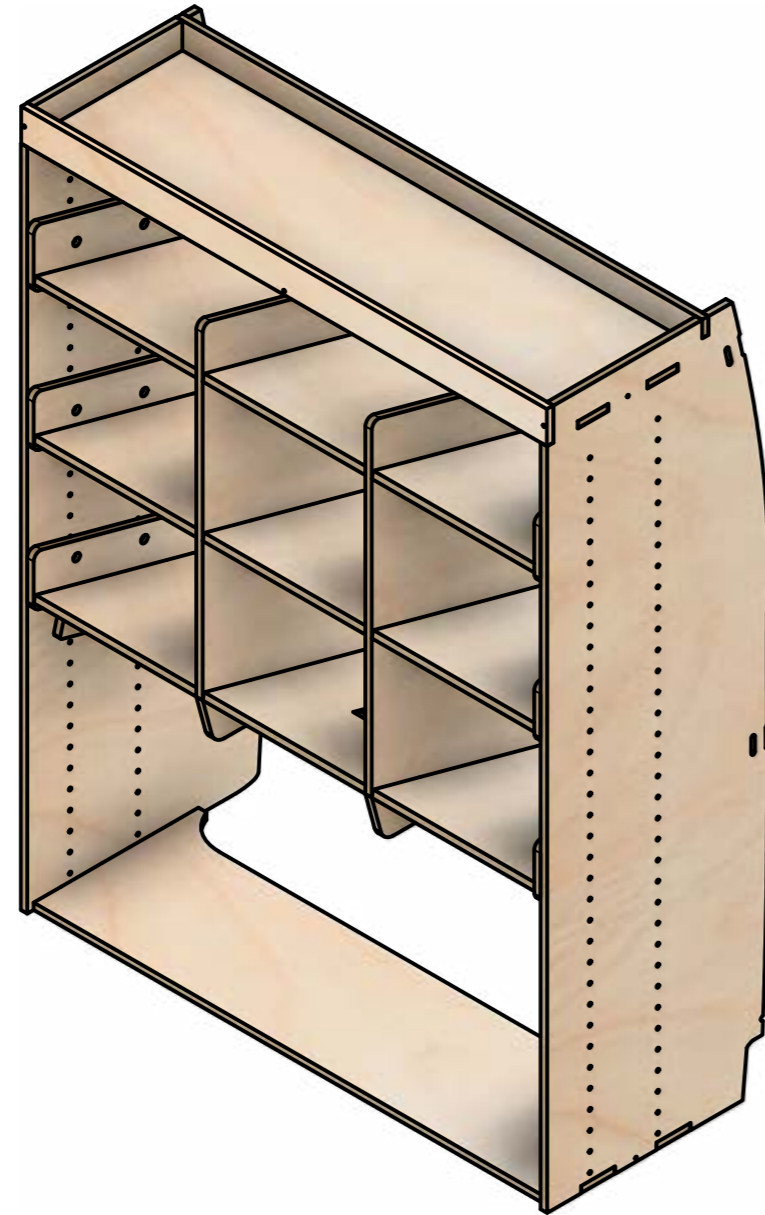
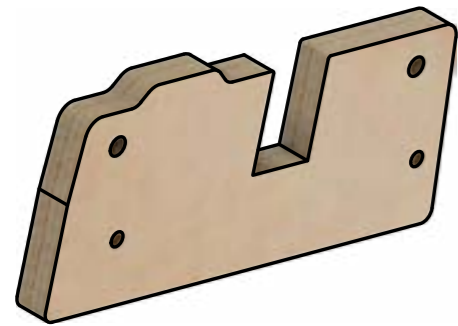

Euro Container Module

If your module has underside clearance, use the larger angled mounting tools with cross supports. If your module sits on the racking base, use the smaller angled mounting tools.

Use the extra holes to fix the mounting tool to the upright for added support.

Once the module is in place, use the holes in the module sides to fix to the uprights.

Tips & Tricks

Ensure the module partitions rest on the base of the unit.

If mounting with underside clearance, always use the relevant cross supports.

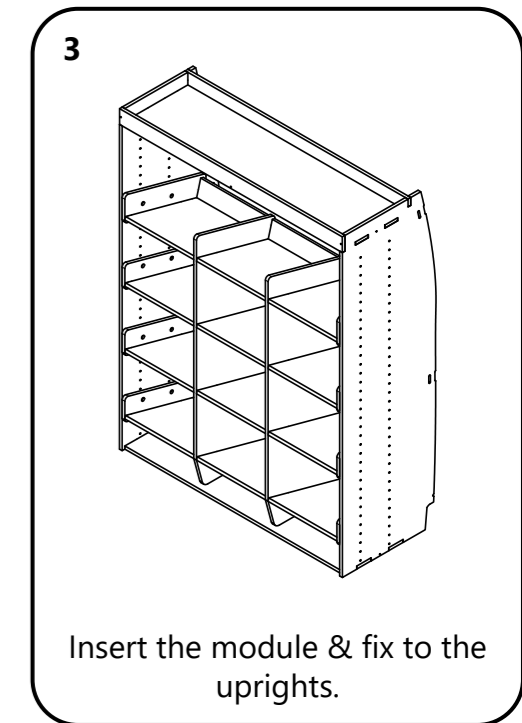
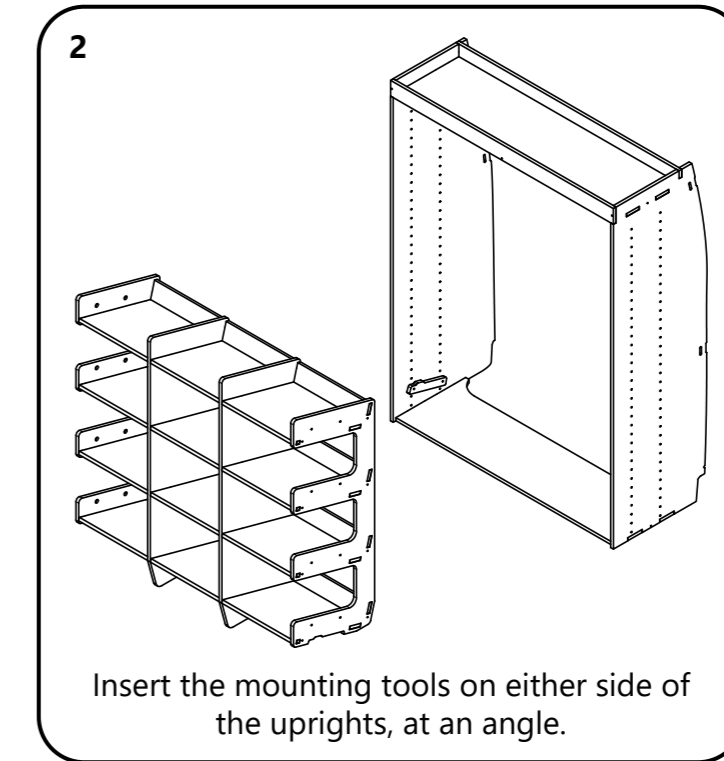
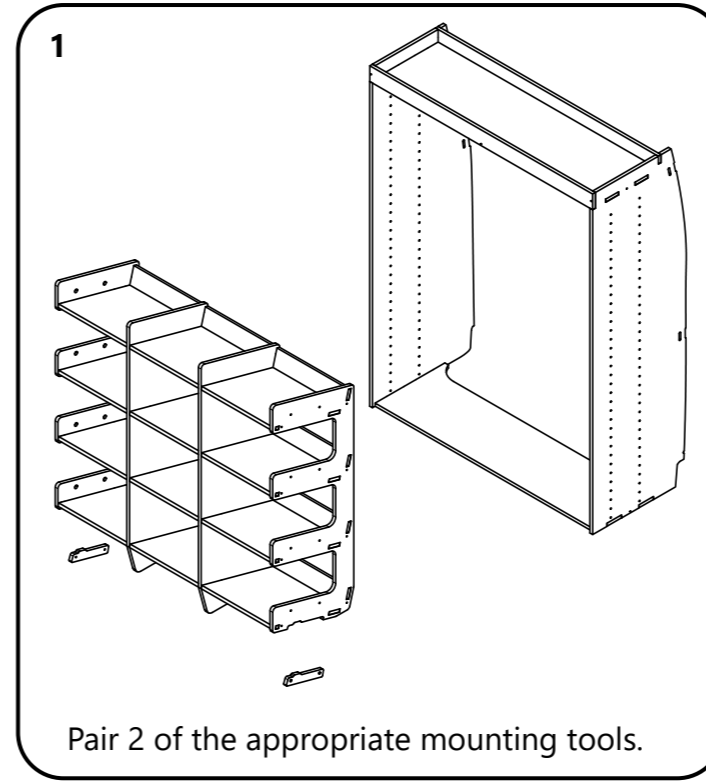
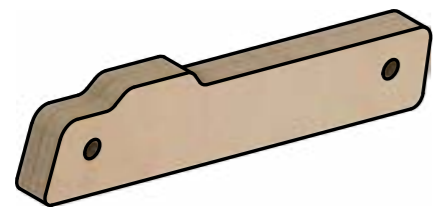

Dual Slanted Open Underside

The dual slanted open underside module uses the larger angled mounting tools. Use these in conjunction with the relevant cross supports to ensure a strong installation.

Tips & Tricks

The underside cross supports can be glued & screwed together for added strength.

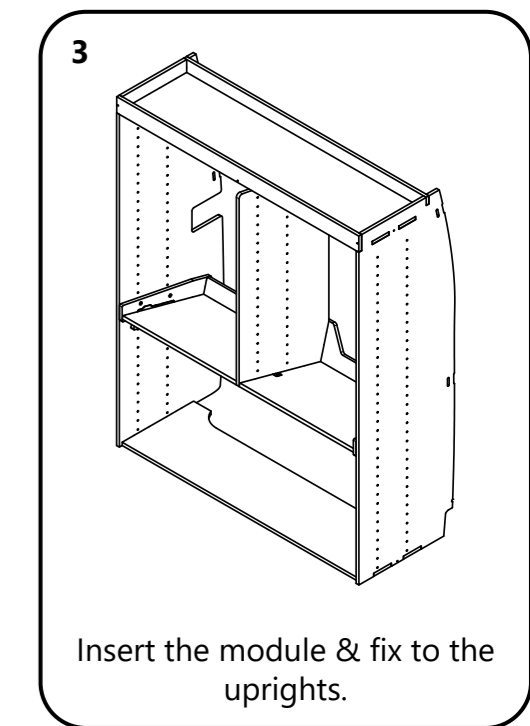
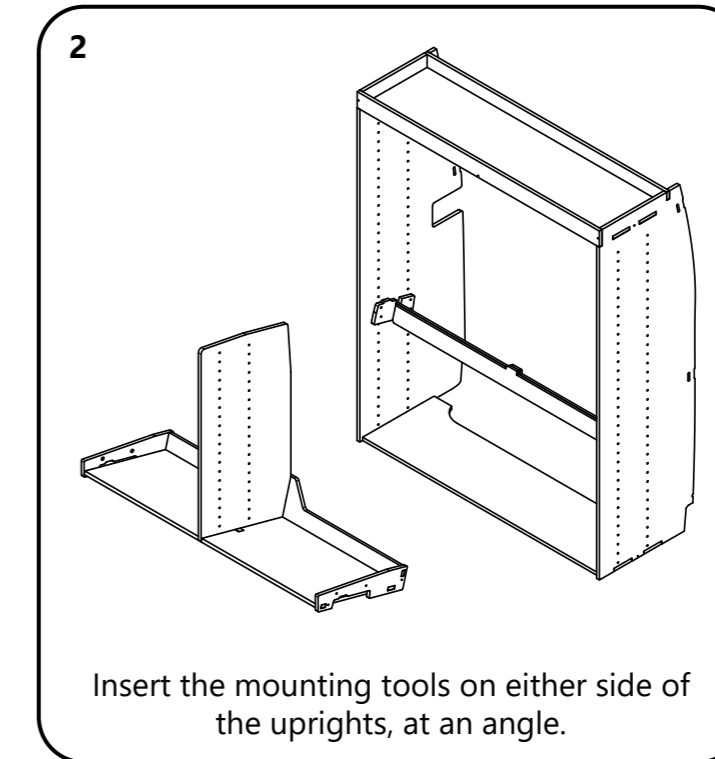
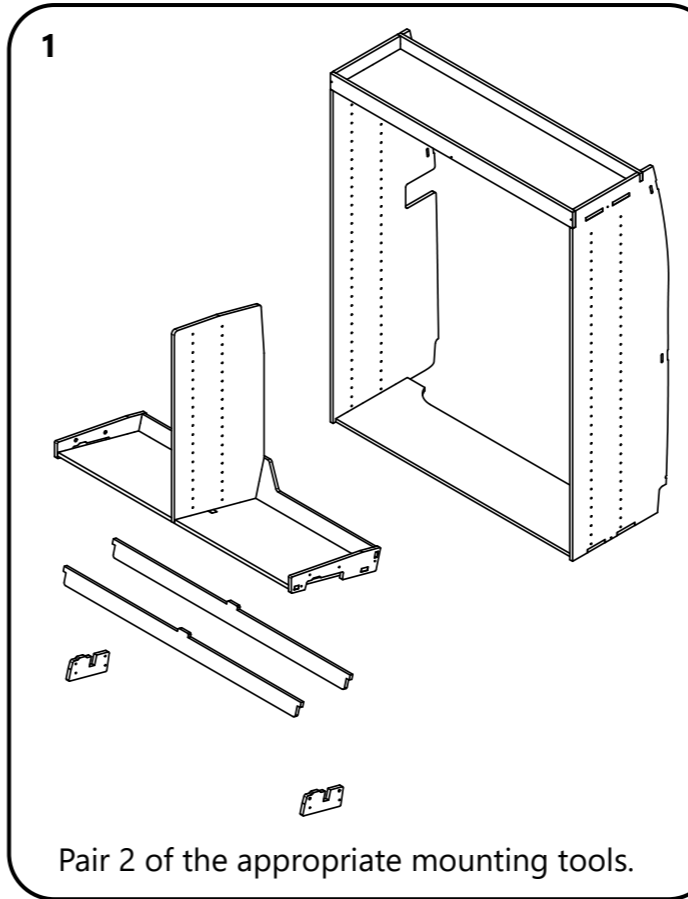
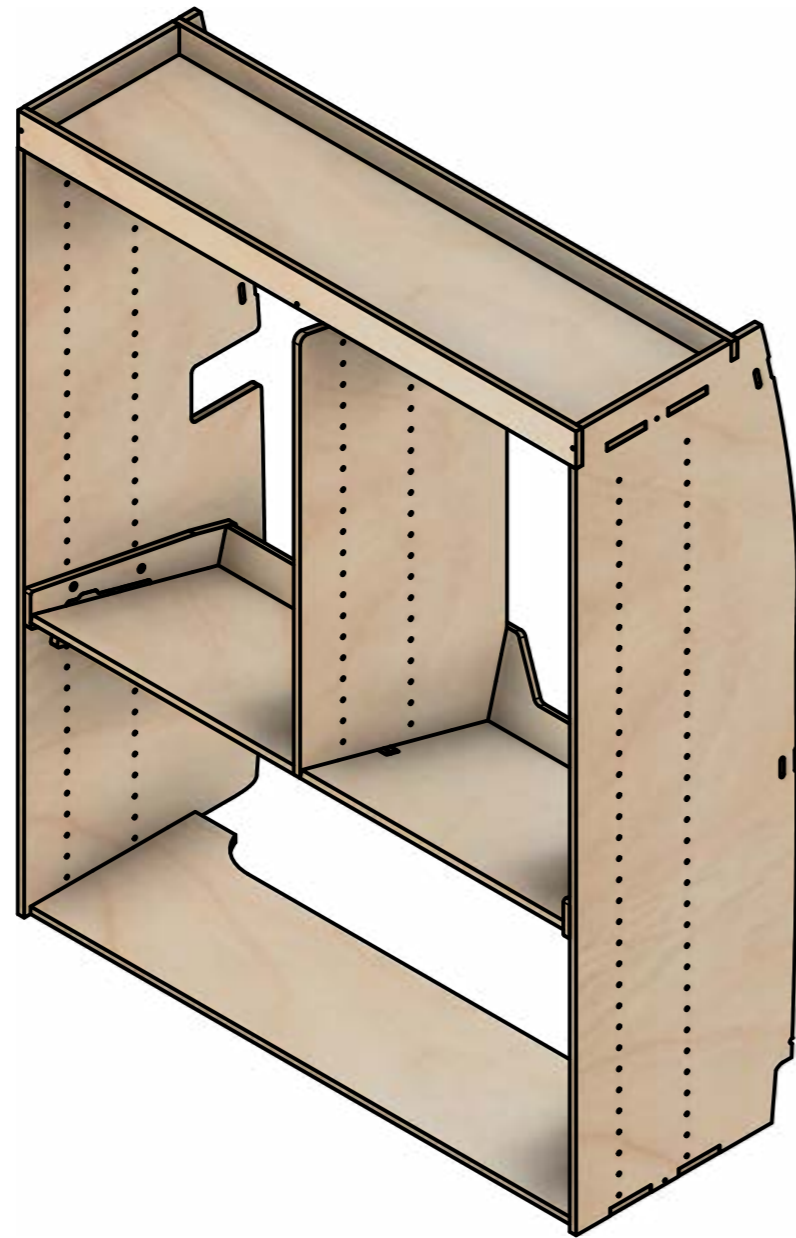
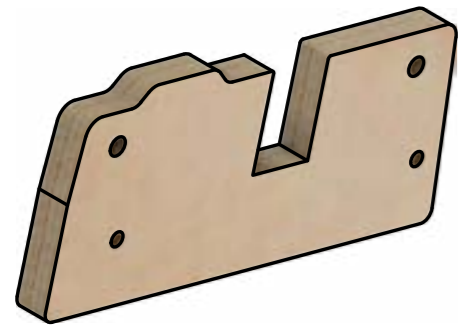

Organiser Module

The Organiser module uses the larger flat mounting tools (seen below). They are symmetrical and do not have a specific left/right.

Use the extra holes to fix the mounting tool to the upright for added support.

Once the module is in place, use the holes in the module sides to fix to the uprights.

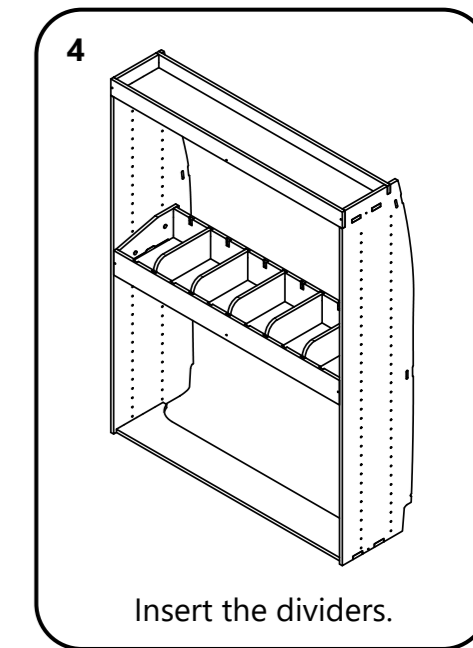
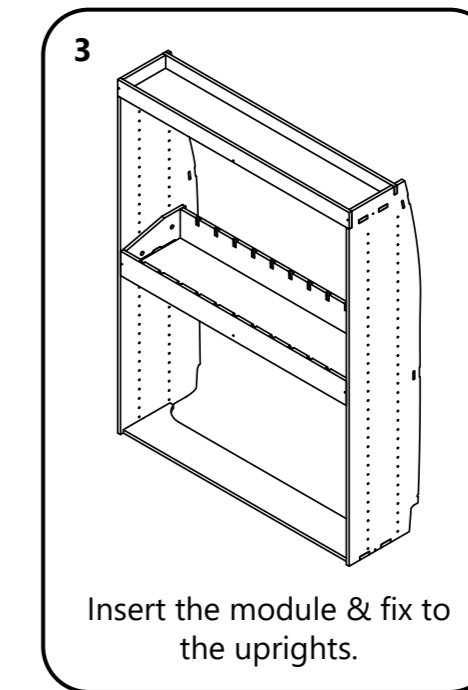
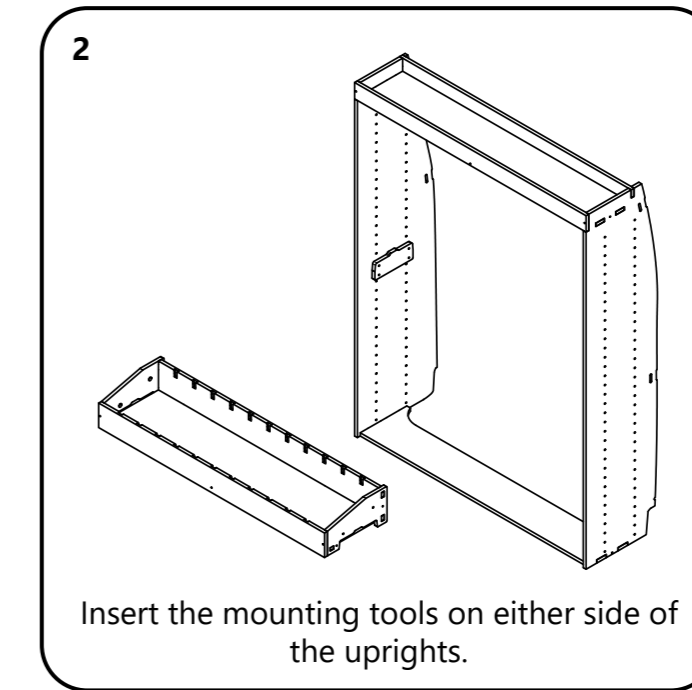
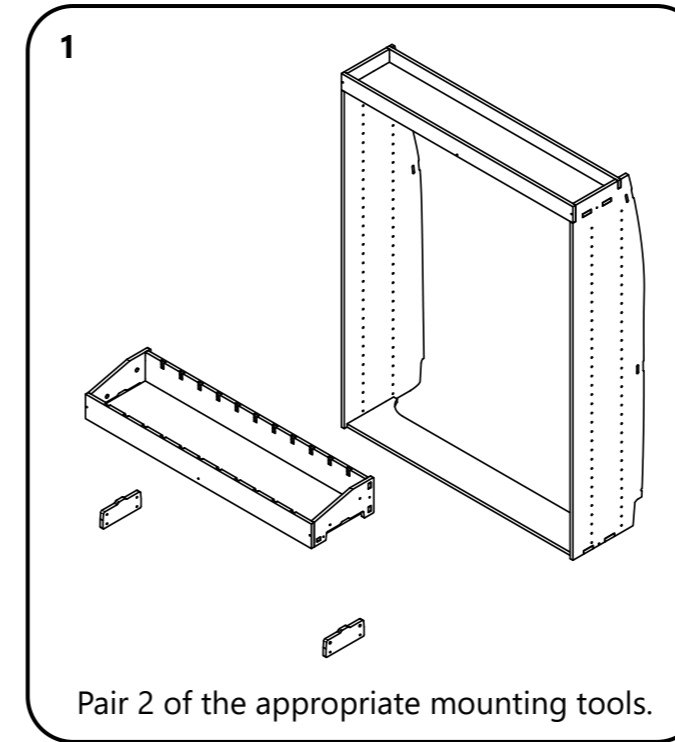
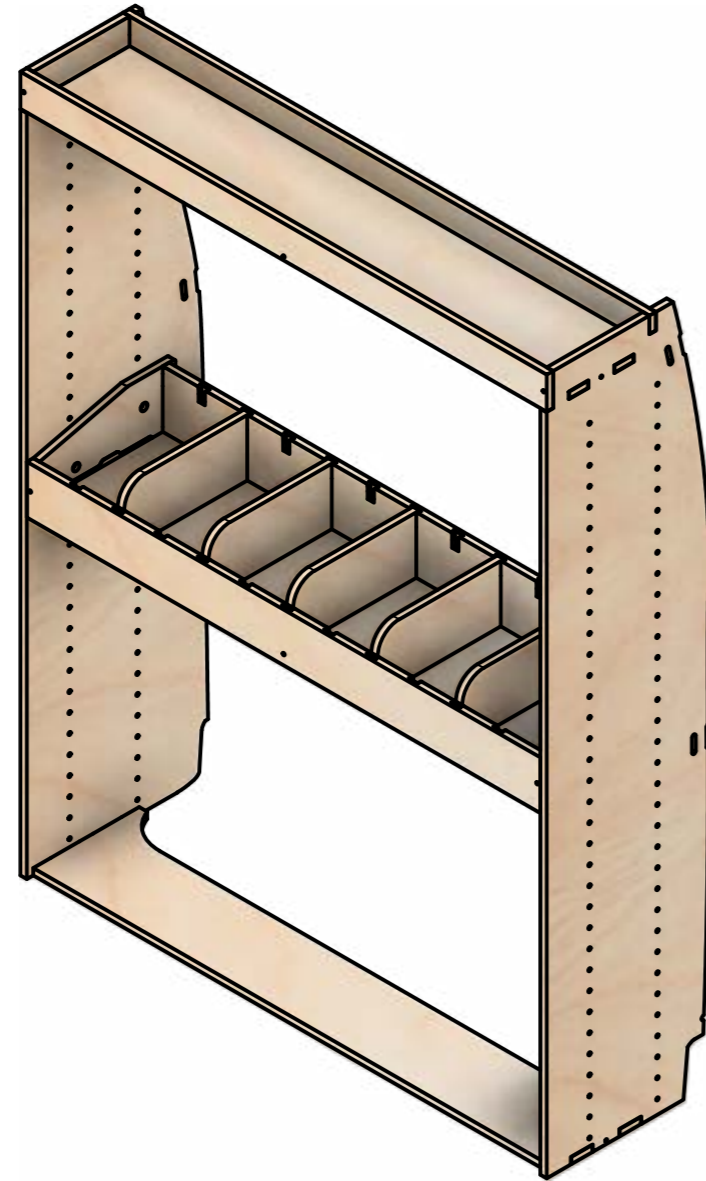
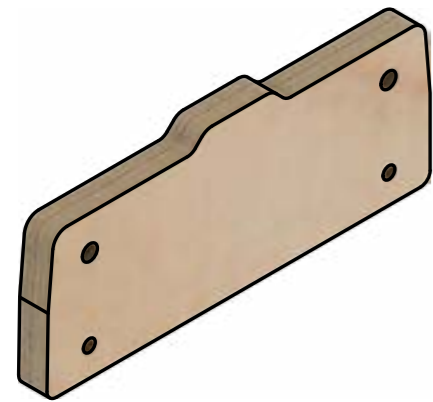

Retainer

The retainers use 2 fixing tools with a single countersunk hole and no pins. The fixing tools fixed to the uprights using countersunk machine screws and then the retainer is fixed with wood screws.

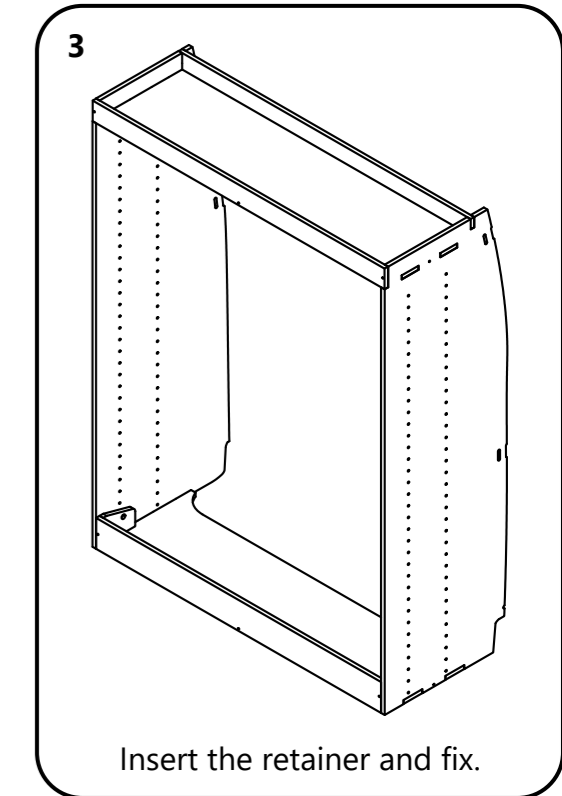
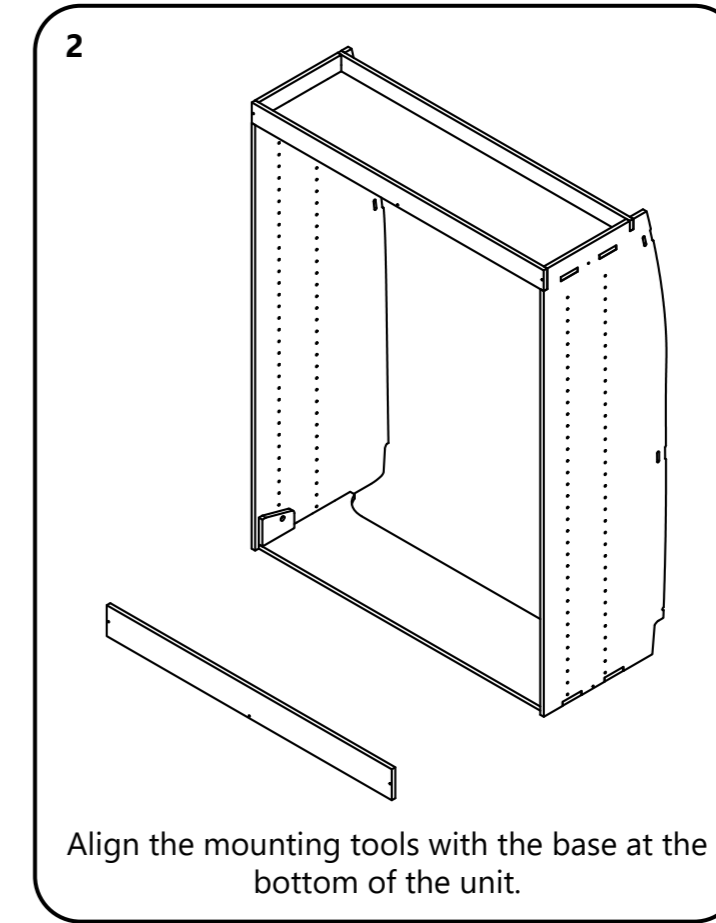
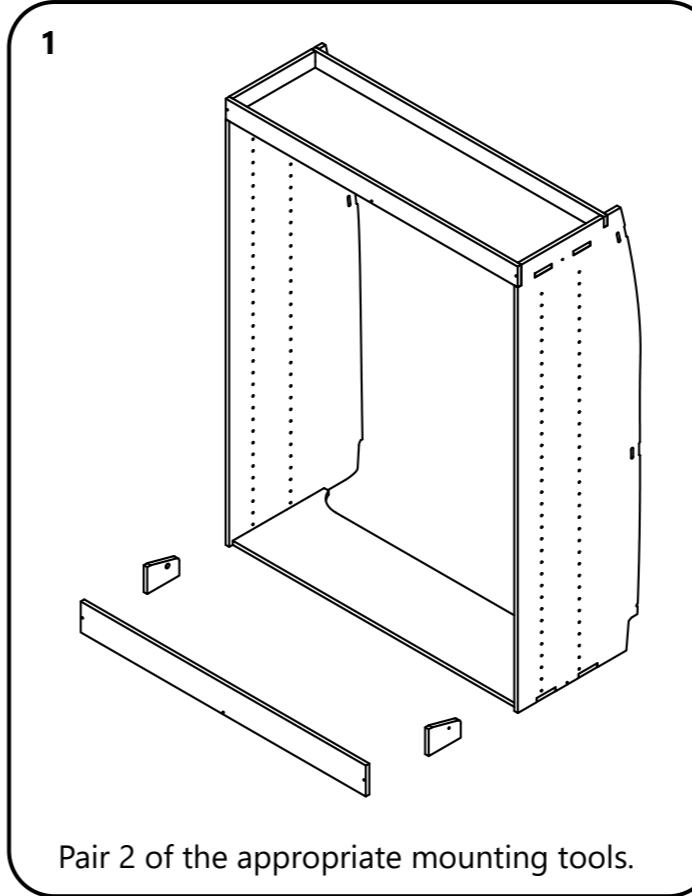
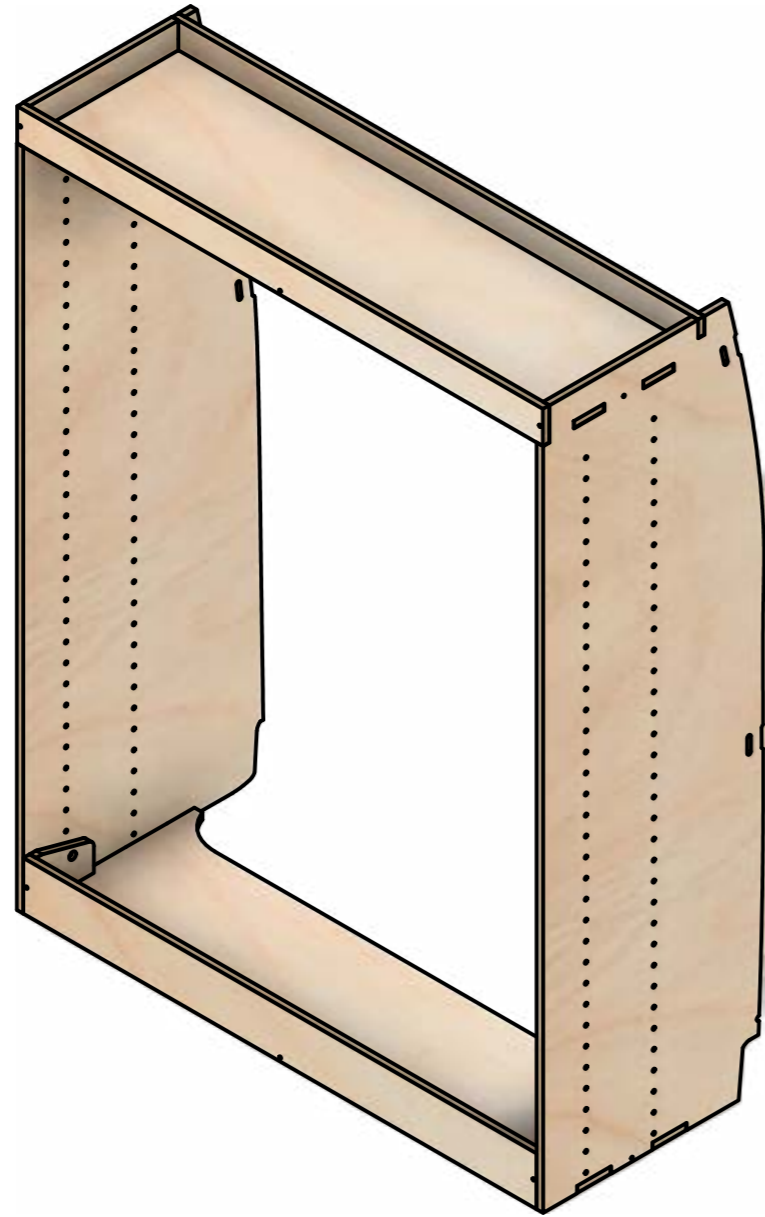
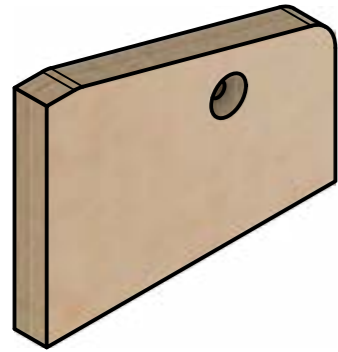

Yoke Vans

info@yoke-van-kits.co.uk

020 8132 9221